



Installation

JENSEN is pleased to assist you in planning your laundry providing excellent consulting, layouts and technical data. Authorized JENSEN distributors or JENSEN engineers should carry out the installation to ensure the correct performance.

Service

In addition JENSEN provides an extraordinary after sales service through a worldwide network of highly qualified Sales and Service Centers and distributors, all with their own maintenance and spare parts services.

Call us...

JENSEN provides a complete range of heavy-duty equipment for the laundry industry, delivered and installed according to your specifications. Please do not hesitate to contact us for further advice and information, or visit www.jensen-group.com

Local contact

www.jensen-group.com

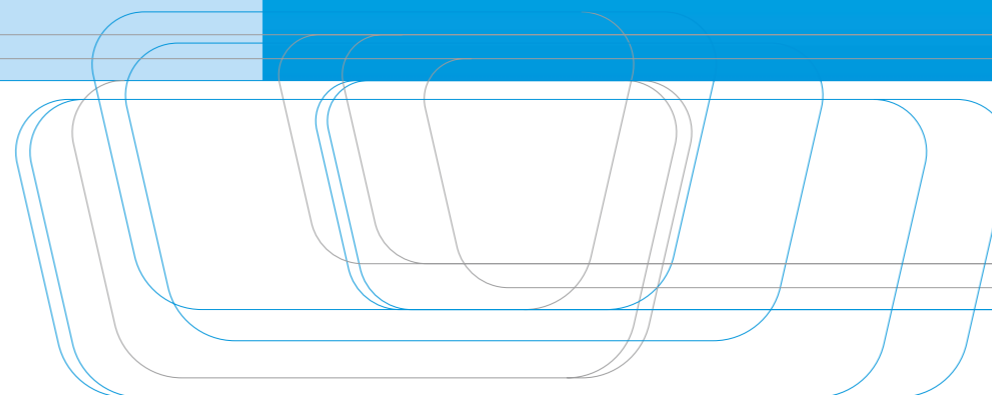

Easy linen separation with the unique

JENSEN CakeBreaker

that breaks up the press cake
into small lots



Model*	CB 1000	CB 1300
Cake diameter (max.)	1005 mm (40")	1300 mm (51")
min. batch weight	30 kg (66 lbs)	70 kg (154 lbs)
Cake height (max.)	300 mm (12")	300 mm (12")
Cycle time (min.)*	50 – 85 sec.	50 – 85 sec.

Dimensions

A: Total width (approx.)	2000 mm (79")	2300 mm (91")
B: Total length (approx.)**	1530 mm (60")	1830 mm (72")
C: Receiving height (min.)	1280 mm (50")	1280 mm (50")
D1: Min. drop height – unloading in line	500 mm (12")	500 mm (12")
D2: Min. drop height – 90°-unloading	600 mm (24")	600 mm (24")
D3: Min. belt height (unloading into linen trolley)	2300 mm (91")	2300 mm (91")
E: Min. height of safety fence (locally)	2000 mm (79")	2000 mm (79")
F1: Min. distance between CB and safety fence (side)	700 mm (28")	700 mm (28")
F2: Min. distance between CB and safety fence (front/end)	600 mm (24")	600 mm (24")

Compressed air (6–10 bar) / (87–145 psi)

Connection	10 DN	10 DN
Consumption (approx.)	300 NI/batch (11 cuft/batch)	450 NI/batch (6 cuft/batch)

Electricity (400 V, 50 Hz)

Connection (approx.)	1,0 kW	1,4 kW
Consumption (approx.)	0,3 kWh/h	0,3 kWh/h
External fuse protection	10 A	10 A
Output of belt motor (approx.)	0,75 kW	1,1 kW
Belt speed	16 m/min (53 ft/min)	16 m/min (53 ft/min)

* Depending on the linen category, batch size and the belt speed of the following conveyor.

** Extensions of the conveyor belt are available on request.

Conveyor 90° behind CakeBreaker

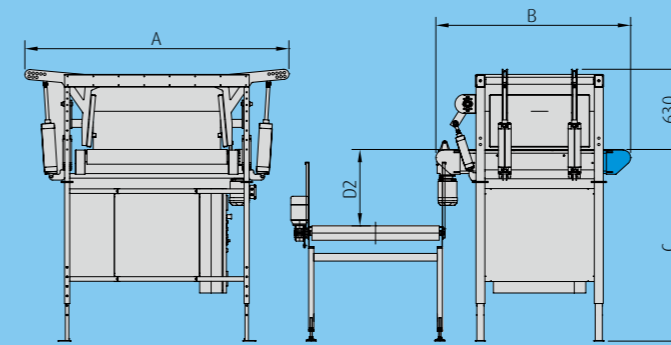

Conveyor in line with CakeBreaker

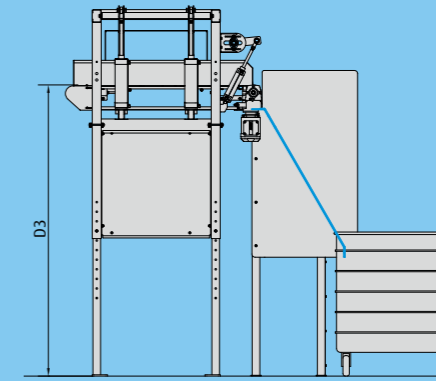
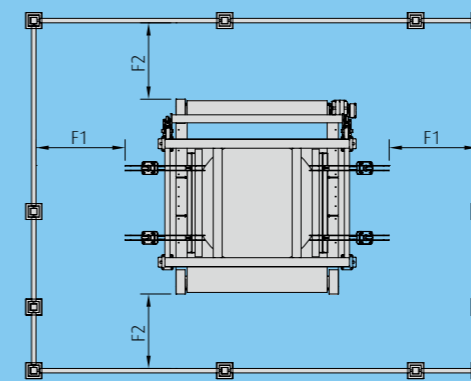
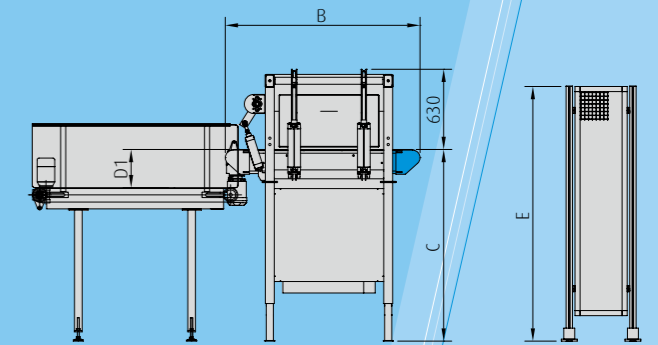

We reserve the right to make changes to the technical data as well as to the machine design in the interest of continual improvement. All consumption and performance figures are approximate and depend on the type of linen, the batch size etc.; they are only applicable on the precondition that the stated flow and operating pressures of the individual media are maintained.

JENSEN CakeBreaker

that breaks up the press cake into small lots

JENSEN CakeBreaker

The JENSEN CakeBreaker was designed to break up pressed cakes of large-piece batches, like sheets, draw sheets and duvet-covers into smaller lumps, thus sparing the tumbler capacity for other purposes. It is a fully automatic, individual cake breaking unit with its own switch panel with PLC-control. The CakeBreaker is designed to be placed in the process behind a water extraction press.

The CakeBreaker receives the linen cake on a conveyor, and by a set of pressing plates operating on both sides of the press cake, the batch is broken up into smaller lumps. These smaller lumps now fall down on a transport conveyor which separates the linen further prior to the transport to the finishing department.

The CakeBreaker is available in two standard sizes for cake diameters of max. 1005 mm (40") (CB 1000) and 1300 mm (51") (CB 1300).

A CakeBreaker built into a lift- or shuttle conveyor is also available as option.

Advantages of the JENSEN CakeBreaker

- replaces the tumbling process of sheets and duvet covers
- spares tumbling capacity for other purposes and therefore increases the drying capacity
- reduces energy consumption
- prevents twisting and tangling of large linen pieces
- increases the capacity of a linen separator (e.g. "JENSEN Viking")
- is easy to install and to operate