



565.717-8526

STIRO COLLI E POLSI

Macchina da stiro elettropneumatica per colli e polsi con discesa verticale della forma superiore e stiro dei polsi con gonfiabile.

La macchina è completa di:

- forma superiore lucida riscaldata elettricamente a discesa verticale
- forma inferiore centrale (stiro collo) rivestita ed aspirante
- forma inferiore destra/sinistra (stiro polsi) dotata di dispositivo gonfiabile
- controllo elettronico della temperatura
- pistola nebulizzatrice da allacciare ad impianto ad acqua
- programmatore TSM display da 3,8" con USB per la programmazione di una o più unità di stiro di qualsiasi tipologia.

565.717-8526

COLLAR AND CUFFS

Electropneumatic machine for pressing collar and cuffs. Inflatable device for cuffs. Vertical descent of upper shape.

The machine is complete with:

- electrically heated polished upper shape by vertical drop
- central lower shape (collar pressing), covered and with vacuum
- lower shape right/left (cuffs pressing) equipped with an inflatable device
- electronic temperature control
- water spraying gun to be connected to hydraulic central plant
- TSM terminal with 3,8" display and USB for the programming of one or more pressing units of any typology.

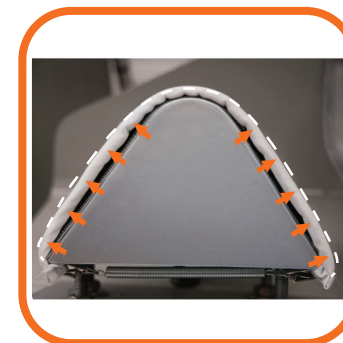

Sistema di air-bag  
Airbag system

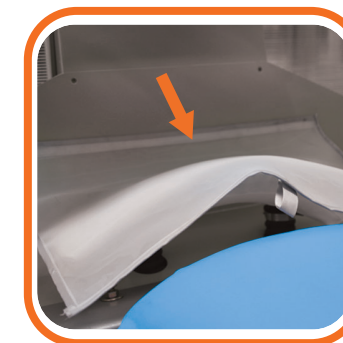

Cover anti-lucido  
Anti shine cover

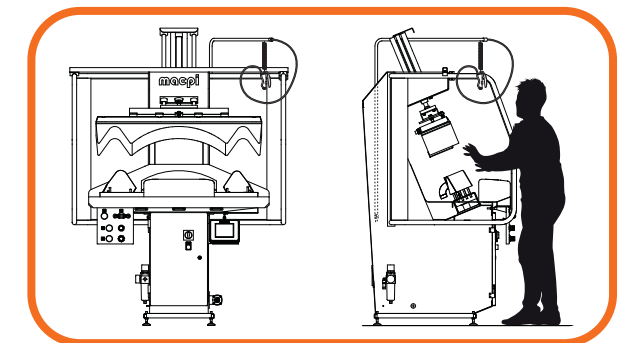

Piano di lavoro ergonomico  
Ergonomic working station

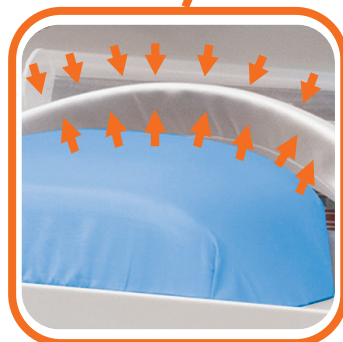

Stiro sotto collo aspirante  
Undercollar area with vacuum



Programmatore Touch screen 3,8" removibile  
3,8" removable touch screen programmer



Technical details

**555.717-8526** Dimension: (mm W x H x D) 1450 x 1930 x 1025 | Weight: 270 Kg  
Compressed air: pipe connection 1x ø12 mm | Pressure 6 ATE | Consumption 52NL/min  
Electric power: 3,6Kw | Consumption 2,5Kw/h